







# *Snap-Trap<sup>®</sup> Tubing Clamps*

*Bul 4291/GB  
July 2005*

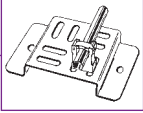

# Snap-Trap® Tubing Clamps

## Contents

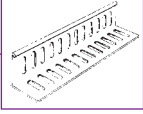
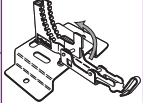
<b>Page 3</b>	Introduction.	
<b>Page 4/5</b>	Advantages.	
<b>Page 6/7</b>	Clamps, Keys and Brackets.	
<b>Page 8</b>	Accessories.	
<b>Page 9</b>	Weld and Tray Rail Brackets.	
<b>Page 10/11</b>	Assembly Instructions.	

All dimensions shown in this catalogue are approximate and subject to change.

### **WARNING**

FAILURE, IMPROPER SELECTION OR IMPROPER USE OF THE PRODUCTS AND/OR SYSTEMS DESCRIBED HEREIN OR RELATED ITEMS CAN CAUSE DEATH, PERSONAL INJURY AND PROPERTY DAMAGE.

This document and other information from Parker Hannifin Corporation, its subsidiaries and authorized distributors provide product and/or system options for further investigation by users having technical expertise. It is important that you analyze all aspects of your application and review the information concerning the product or system in the current product catalog. Due to the variety of operating conditions and applications for these products or systems, the user, through its own analysis and testing, is solely responsible for making the final selection of the products and systems and assuring that all performance, safety and warning requirements of the application are met.

The products described herein, including without limitation, product features, specifications, designs, availability and pricing, are subject to change by Parker Hannifin Corporation and its subsidiaries at any time without notice.

### **Offer of Sale**

The items described in this document are available for sale by Parker Hannifin Corporation, its subsidiaries or its authorized distributors. Any sale contract entered into by Parker will be governed by the provisions stated in Parker's standard terms and conditions of sale (copy available upon request).

## Principle

Snap-Trap® is an innovative clamp, designed to radically simplify the installation and maintenance of instrumentation tubing. Its unique, one piece, design allows quick and easy fitting to cable trays, brackets and angle iron alike. The Snap-Trap® will fit slotted cable trays with dimensions as indicated on page 7. It can also be mounted to any other design of trays with the aid of brackets as shown in the examples on page 7.

Snap-Trap® fully complies with the Norwegian offshore standards "NORSOK".

Section 8.3 of the NORSOK standard Z-CR-010 which covers the installation of instrumentation tubing states that:

Tubing clamps shall be made of non-corrosive material, stainless steel AISI 316 or flame retardant plastic.

Galvanic corrosion between tubing and tubing support system shall be avoided. The tubing clamp shall, when installed, not allow for water/sea water to be accumulated between tubing clamp and tubing, this is to avoid crevice corrosion.

## Benefits

With over one million tube clamps already installed Snap-Trap® is a field proven solution that offers significant cost savings.

- **Reduced installation time, by up to 40%.**
- **Reduced maintenance costs, by up to 80%.**
- **Reduced purchasing and inventory costs.**
- **Reduced tooling costs.**

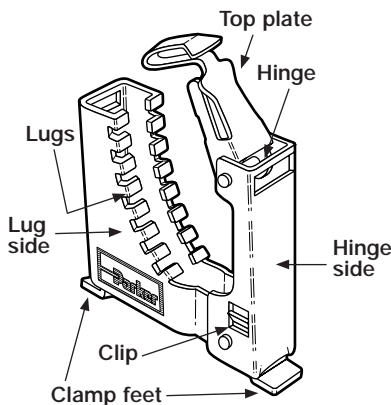

## Easy mounting

Snap-Trap® mounts directly on popular field ladders and trays. A hinge allows the feet to move together before locking the clamp in place. Clamps can also be repositioned in seconds - again without special tools. So, repairs, refurbishment or routine maintenance may be accomplished more speedily, multiplying savings. Economic accessories adapt Snap-Trap® for unusual mountings, ensuring it can be used in any situation: greenfield or existing plant.



*Hinged base locks clamp in place, and allows repositioning*

## 'Snap' action

The arm grips tubes by means of a ratchet-style mechanism - there are no nuts or bolts to tighten. A tube can be clamped in a second - and the flexibility of this 'snap' action allows Snap-Trap® to accommodate a wide range of tube sizes. The action locks tubing securely; steel would have to shear before it could break free. A tool is available for ensuring the ratchet closes to the optimum tightness.

# Snap-Trap® Tubing Clamps



Snap-Trap® is a clamp which radically simplifies the installation and maintenance of instrumentation tubing. Thanks to its unique one-piece design, it can be fitted or moved in a tiny fraction of the time of competitive systems - minimizing labour.

## Advantages

- Simple and quick to assemble.
- Complies fully to NORSOK standard Z-CR-010.
- Compact clamp in stainless steel.
- No loose parts.
- Snap-Trap® tubing clamp is erected without using traditional tools. (No slippage of spanners on nut or bolt hexagons).
- No bolts to be fastened to the ladder/tray etc. (i.e. easy access).
- Automatic compensation for various tube dimensions.
- No additional spare parts need to be ordered.
- Snap-Trap® tubing clamp is available in 2 sizes which covers both metric and imperial tubing.
- Stackable.
- Flexible.
- Test data available on request.

Snap-Trap® delivers immediate savings, minimizing purchasing overheads and cutting assembly labour costs by as much as 80%!

Savings multiply throughout Snap-Trap®'s life-cycle:

**Time savings:** on a witness trial against competitive systems, 3 tube runs requiring 6 Snap-Trap®s were completed in less than 2 minutes - compared with over 5 and 11 minutes - a remarkable gain in productivity.

## 2 parts vs. 29!

Snap-Trap® competes with multi-piece clamps requiring up to 6-12 parts - cutting weight dramatically. And, just two sizes handle all metric/imperial tubing to 25mm/1 inch, streamlining specification, purchasing and stocking.

	Clamp A	Clamp B	Snap-Trap®
# parts for one tube size	12	7	1
# parts for range of tubing	29	12	2
typical assembly time for six clamps	11 min 35 secs	5 min 17 secs	1 min 55 secs

# Snap-Trap® Tubing Clamps



## Field proven

Designed by an offshore contractor, the clamp is field-proven with millions installed in some of the harshest conditions in the world. By switching to Snap-Trap®, such users have saved a great deal of labour; Parker estimates at least 40% during installation alone. With clamps required for typically every 60cm of instrument tubing, initial savings of tens of thousands of dollars are easily achievable for a major project like a platform or new processing plant.

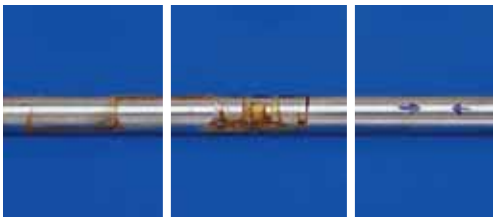

Clamp B

Clamp A

Snap-Trap®

**Less corrosion:** This 700-hour salt spray test (to ASTM B117 - photo left) demonstrates Snap-Trap®'s superiority to alternatives, supporting the design of instrumentation systems for harsh environments, and standards such as NORSOK Z-CR-010. Clamp A in the photograph to the left shows what can happen to conventional clamps after extended service; this clamp was removed from a North Sea platform after less than five years service because it is at the point of failure.

**Quicker maintenance:** Snap-Trap® can be opened in a second or disassembled for re-use elsewhere, speeding routine maintenance, upgrades and refits.



The problem Snap-Trap® solves

**Less stock:** with just two parts for the spectrum of instrumentation tube sizes - compared with as many as 29 for alternative clamps - purchasing and stockholding is streamlined, and costs are minimized through commonality.



Stainless steel and small contact points minimize opportunity for corrosion

**Simpler purchasing:** just two Snap-Trap® sizes handle the range of tubes up to 1 inch/25mm - compared with as many as 29 for a competitive system - streamlining purchasing, delivery and stocking.

# Snap-Trap® Tubing Clamps

## Clamps, Keys and Brackets

Description	Size	Part Number	A	B	C
Small Tube Clamp to suit 6-12mm tube	6mm (1/4") to 12mm (1/2")	ST-TC-01	27	27	12
Large Tube Clamp to suit 14-25mm tube	14mm (5/8") to 25mm (1")	ST-TC-02	47	47	15
Snap-Trap® assembly key for ST-TC-01	Small clamp key	TC-01-KEY			
Snap-Trap® assembly key for ST-TC-02	Large clamp key	TC-02-KEY			
Small bracket for use with ST-TC-01	75 x 40mm	ST-MC-S			
Double bracket for ST-TC-01	75 x 75mm	ST-MC-D			
Large bracket for ST-TC-02	65 x 60mm	ST-MC-BIG			
Side rail cable ladder bracket	75 x 53mm	ST-TUB			

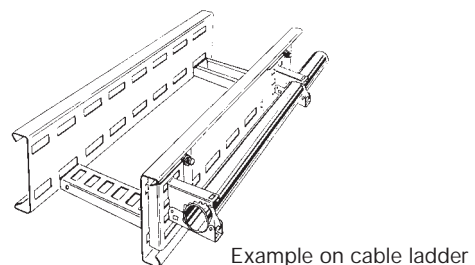
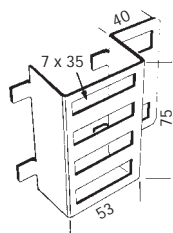
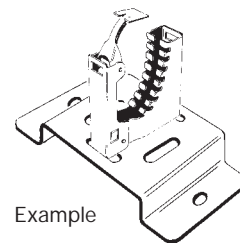
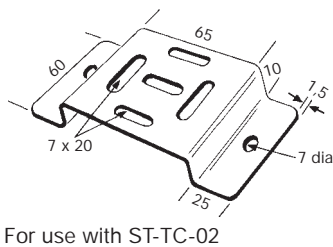
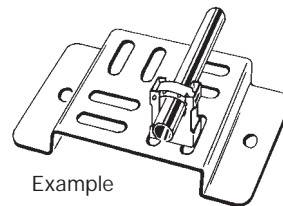
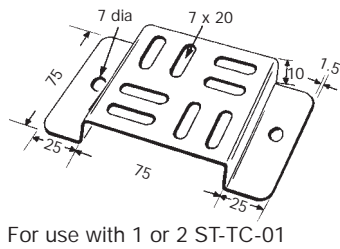
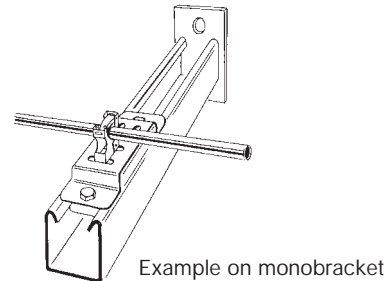
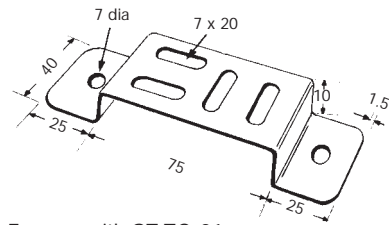
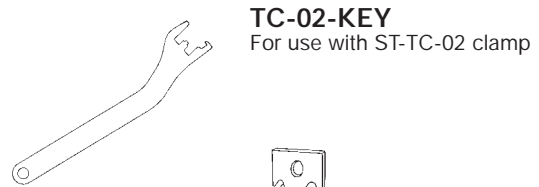
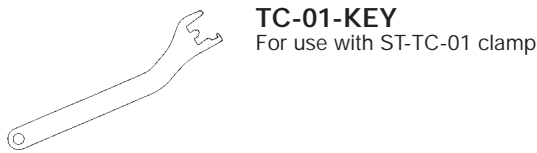
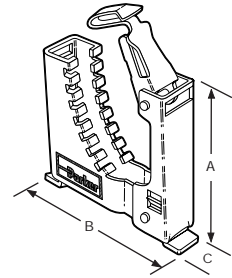

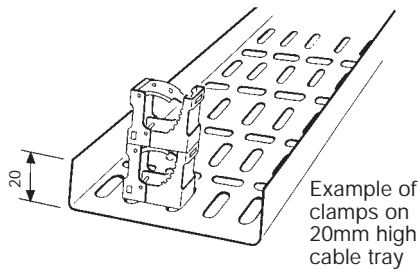

Standard length 3 metres

Example of clamps on 20mm high cable tray

## Cable Trays 20mm high x 3 metres long

Description	Size	Part Number
KB Type Cable Tray	50mm wide x 20mm high	KB 50/20
KB Type Cable Tray	100mm wide x 20mm high	KB 100/20
KB Type Cable Tray	150mm wide x 20mm high	KB 150/20
KB Type Cable Tray	200mm wide x 20mm high	KB 200/20
KB Type Cable Tray	300mm wide x 20mm high	KB 300/20
KB Type Cable Tray	400mm wide x 20mm high	KB 400/20
KB Type Cable Tray	500mm wide x 20mm high	KB 500/20
KB Type Cable Tray	600mm wide x 20mm high	KB 600/20

## Cable Tray slot dimensions

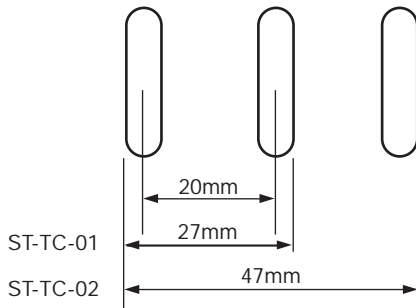

ST-TC-01

ST-TC-02

## Cable Trays 40mm high x 3 metres long

Description	Size	Part Number
KB Type Cable Tray	50mm wide x 40mm high	KB 50/40
KB Type Cable Tray	100mm wide x 40mm high	KB 100/40
KB Type Cable Tray	150mm wide x 40mm high	KB 150/40
KB Type Cable Tray	200mm wide x 40mm high	KB 200/40
KB Type Cable Tray	300mm wide x 40mm high	KB 300/40
KB Type Cable Tray	400mm wide x 40mm high	KB 400/40

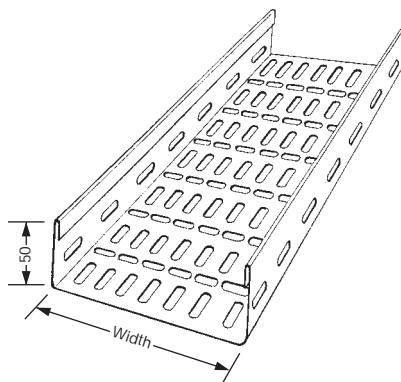

## Cable Trays 50mm high with return flange

Description	Size	Part Number
KBR Type Cable Tray with return flange	50mm wide x 50mm high	KBR 50
KBR Type Cable Tray with return flange	100mm wide x 50mm high	KBR 100
KBR Type Cable Tray with return flange	150mm wide x 50mm high	KBR 150
KBR Type Cable Tray with return flange	200mm wide x 50mm high	KBR 200
KBR Type Cable Tray with return flange	300mm wide x 50mm high	KBR 300
KBR Type Cable Tray with return flange	400mm wide x 50mm high	KBR 400

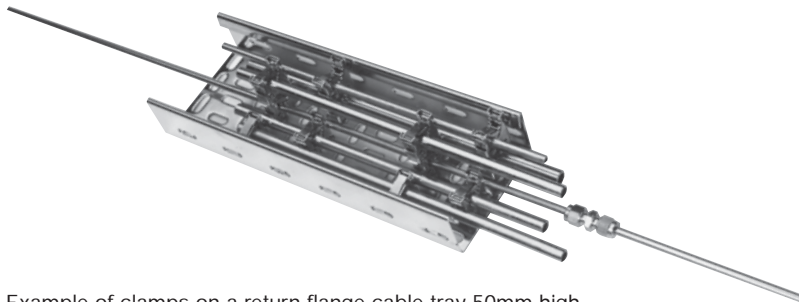

Example of clamps on a return flange cable tray 50mm high.

# Snap-Trap® Tubing Clamps

## Accessories



Locking bolt



Pan head screw

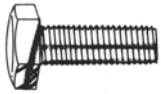

Hexagon head set screw



Plain nut



Flange nut



Flat washer



Lock washer



Star washer

## Stainless Steel Nuts, Washers & Bolts

Description	Size	Part Number
Locking Bolt	M6 x 16mm long	M6LBX16-316
Locking Bolt	M6 x 20mm long	M6LBX20-316
Pan Head Screw	M6 x 16mm long	M6PHSX16-316
Pan Head Screw	M6 x 20mm long	M6PHSX20-316
Pan Head Screw	M6 x 25mm long	M6PHSX25-316
Pan Head Screw	M6 x 30mm long	M6PHSX30-316
Hexagon Head Set Screw	M6 x 16mm long	M6HHSSX16-316
Hexagon Head Set Screw	M6 x 20mm long	M6HHSSX20-316
Hexagon Head Set Screw	M6 x 25mm long	M6HHSSX25-316
Plain Nut	M6	M6PLNUT-316
Flange Nut	M6	M6FLNUT-316
Flat Washer	M6	M6FLWASHER-316
Lock Washer	M6	M6LKWASHER-316
Star Washer	M6	M6STWASHER-316



## Weld & Tray Rail Brackets

Description	Size	Part Number	Length "L" (mm)
Weld Rail 3 metres long	44 x 27mm with 13mm return	ST-WR-0	3000
Weld Rail 57mm long	44 x 27mm with 13mm return	ST-WR-1	57
Weld Rail 217mm long	44 x 27mm with 13mm return	ST-WR-2	217
Weld Rail 297mm long	44 x 27mm with 13mm return	ST-WR-3	297
Tray Rail 817mm long	44 x 13mm with 13mm return	ST-TR-0	817
Tray Rail 97mm long	44 x 13mm with 13mm return	ST-TR-1	97
Tray Rail 137mm long	44 x 13mm with 13mm return	ST-TR-2	137
Tray Rail 197mm long	44 x 13mm with 13mm return	ST-TR-3	197
Splice Plate	45 x 40mm x 200mm long	SP-SM/20	20
Splice Plate	45 x 20mm x 200mm long	SP-SM/40	40

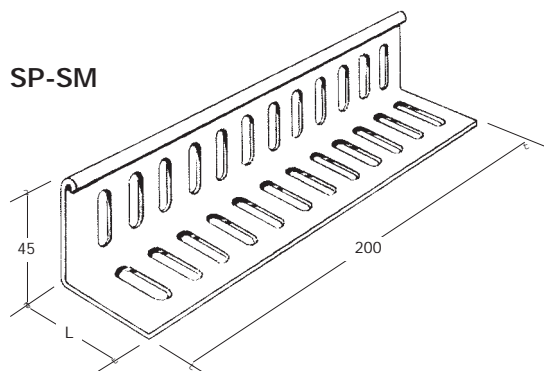
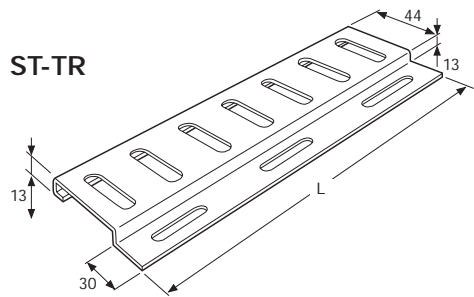
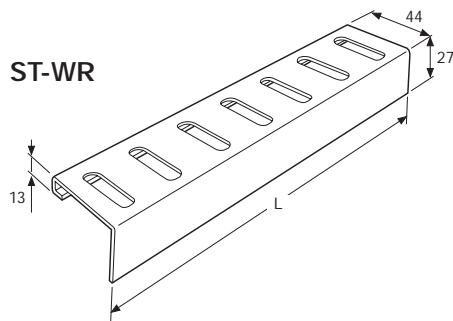

# Snap-Trap® Tubing Clamps

## Assembly instructions

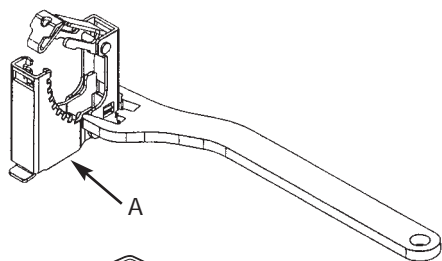

1. Open clamp fully by using the assembly key to release the clip (TC-02 only). TC-01 can be opened simply by squeezing the clamp at point A by hand.

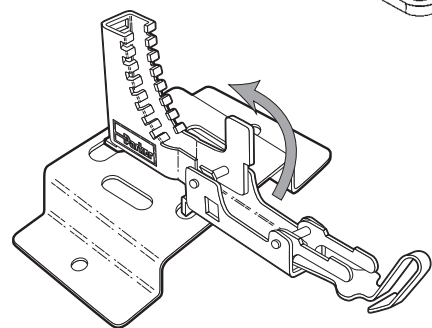

2. Insert clamp feet into the slots on the bracket or trays.

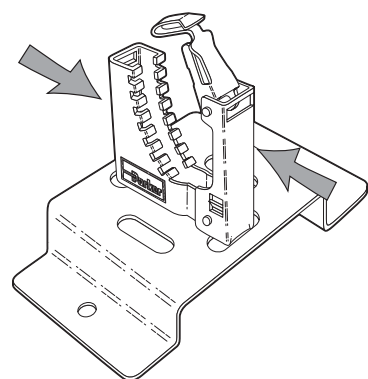

3. Once feet are in position, simply snap the two clamp sides together.

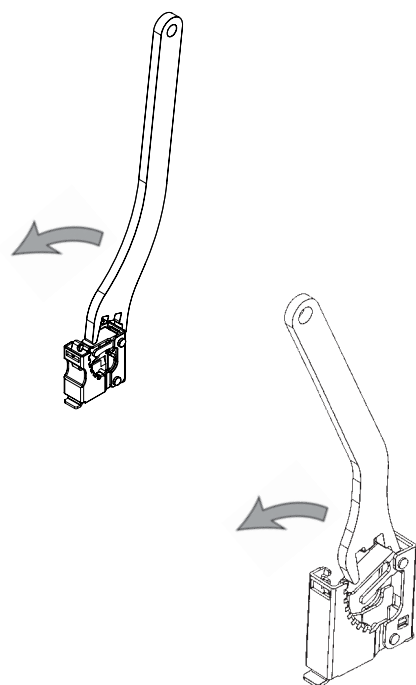

### To assemble tubing into the Snap-Trap® tube clamp ST-TC-01 (6mm - 12mm / 1/4" - 1/2")

Position tubing into the clamp and hook the assembly key at the back of the clamp.

Apply pressure until the clamp top plate engages behind the lugs on the lug side of the clamp. Ensure that the top plate is located firmly against the tubing.

The top plate is designed to cater for any tolerance variants within the tube.

### To assemble tubing into the Snap-Trap® tube clamp ST-TC-02 (14mm - 25mm / 5/8" - 1")

Position tubing into the clamp and hook the assembly key at the hinge part of the clamp.

Apply pressure until the clamp top plate engages behind the lugs on the lug side of the clamp. Ensure that the top plate is located firmly against the tubing.

The top plate is designed to cater for any tolerance variants within the tube.

# Snap-Trap® Tubing Clamps

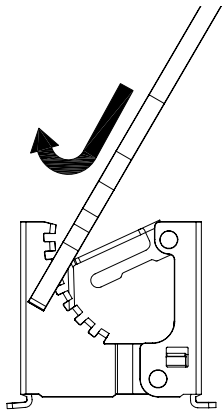

## To disassemble or reposition the Snap-Trap® tube clamp

Using the assembly key, apply pressure to ease the top plate away from the tube and the clamp lugs.

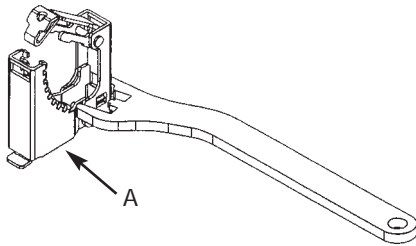

To remove the clamp from the tray or bracket, press the release clip with the assembly key (TC-02 only). TC-01 can be released by squeezing at point A by hand.

## Additional notes when mounting clamps onto cable trays

When mounting clamps in any tubing run, ensure all of the clamps are mounted with their hinges facing the same way. This will ensure there is no twist transmitted to the tubing run.

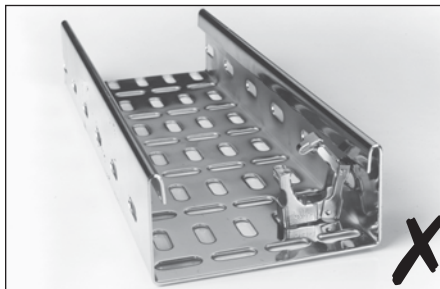

Do not mount clamp with hinge next to side of cable tray.

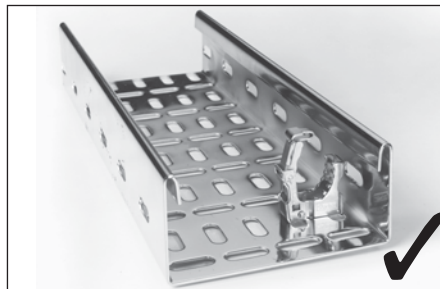

Ensure clamp hinge is away from the cable tray side.

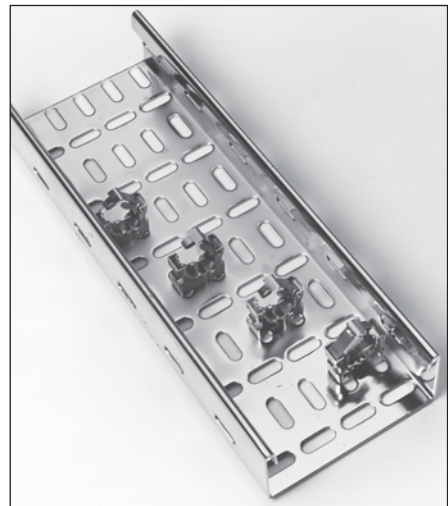

When mounting clamps to take more than one tube run, stagger the clamps in the tray ensuring that the hinges are away from the sides of the cable tray.

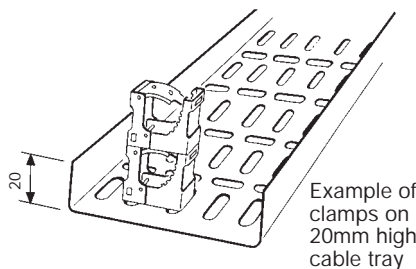

## To stack mount the Snap-Trap® tube clamp

Snap-Trap® tubing clamps can be stack mounted on to each other simply by following the same instructions as those for mounting on to brackets or cable trays.

© Copyright 2005, Parker Hannifin Corporation. All rights reserved.



---

**Parker Hannifin Corporation**  
Instrumentation Products Division  
1005 A Cleaner Way  
Huntsville, AL 35805  
USA  
Tel: (256) 881-2040  
Fax: (256) 881-5072  
[www.parker.com/ipdus](http://www.parker.com/ipdus)

**Parker Hannifin plc**  
Instrumentation Products Division  
Riverside Road  
Pottington Business Park  
Barnstaple, Devon EX31 1NP  
England  
Tel: +44 (0)1271 313131  
Fax: +44 (0)1271 373636  
Email: [ipd@parker.com](mailto:ipd@parker.com)  
[www.parker.com/ipd](http://www.parker.com/ipd)