

Tee Filters (FT Series)

Catalog 4130-FT
Revised, May 2003



FT Series Tee Filters

Introduction

Parker FT Series Tee Filters are designed for protection of instrumentation systems from undesirable materials. Component changes or repair and maintenance can admit dirt, chips, or other contaminants to the small bore tubing.

Features

- Filter element replacement achievable without removing filter from installation
- Compact, high strength forged body design with effective filtration areas of:
 - FT4 – 1.57 sq in (1013 sq mm)
 - FT8 – 2.53 sq in (1632 sq mm)
- Stainless steel and brass construction
- Standard sintered metal micron ratings: 1, 5, 10, 50, and 100
- Optional 250 and 450 micron wire cloth filter elements
- Optional bypass enables a continuous self cleaning flow around the element
- Port connections include male and female NPT, CPI™, A-LOK®, UltraSeal, and VacuSeal

Specifications

- **Pressure Ratings:**
 - With Elastomeric and Metallic Seals:
 - Stainless Steel – 6000 psig (414 bar) CWP
 - Brass – 2000 psig (138 bar) CWP
 - With PTFE Seals:
 - Stainless Steel – 4000 psig (276 bar) CWP
 - Brass – 2000 psig (138 bar) CWP

Materials of Construction

Item #	Part	Stainless Steel Filter	Brass Filter
1	Body	ASTM A 182 TYPE F316	ASTM B 283 Alloy C37700
2	Washer	316 Stainless Steel	
3	Nut	ASTM A 479 TYPE 316	ASTM B 16 Alloy C36000
4	Cap	ASTM A 479 TYPE 316	ASTM B 16 Alloy C36000
5	Retainer Ring	PH 15-7 Mo Stainless Steel	
6	Spring	316 Stainless Steel	
7	Seal	Fluorocarbon Rubber*	
8	Element	316 Stainless Steel	

* Optional seal materials are available. See the How to Order section.
Lubrication: Silicone base

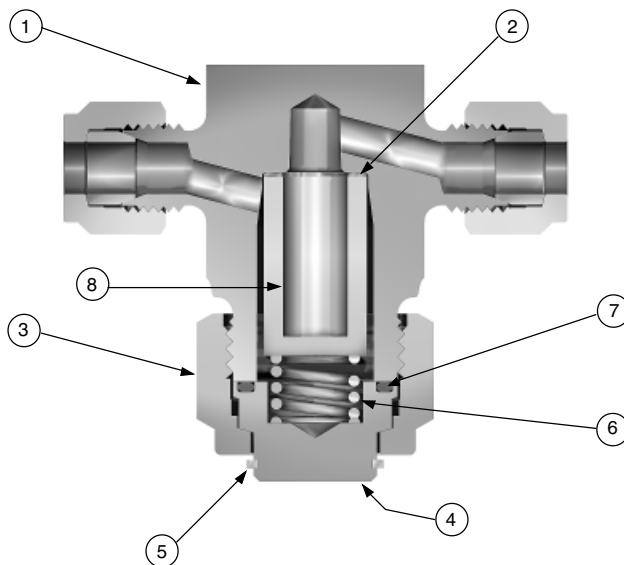

Model Shown: 4Z-FT4-10-BN-SS

Pressure Rating and Tubing Selection:

For working pressures of A-LOK® and CPI™ tube connections, please see the [Instrument Tubing Selection Guide \(Bulletin 4200-TS\)](#), found in the Technical Section of the Parker Instrumentation Process Control Binder, or the Parker Instrument Tube Fitting Installation Manual (Bulletin 4200-B4).

For working pressures of valves with external or internal pipe threads, please see [Catalog 4260, Instrumentation Pipe Fittings](#).

Definitions

Filter Element – The component within the filter which captures media contamination.

Filtration Area – The surface area of the filter element available to capture contamination.

Micron – A unit of measure used to indicate the mean pore diameter of the filter element or the mean particle diameter of media contamination.

One micron = 0.00004 inch or 0.0010 mm

Installation

Best installation practice is to orient the cap downward. This helps to prevent contaminants from entering the system during element change.

FT Series Tee Filters

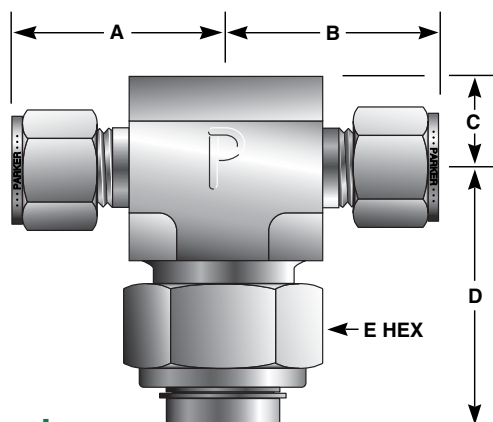

Model Shown: 4Z-FT4-10-BN-SS

Available End Connections

A-Two ferrule A-LOK® compression port



Z-Single ferrule CPI™ compression port



M-ANSI/ASME B1.20.1 External pipe threads



F-ANSI/ASME B1.20.1 Internal pipe threads



Q-UltraSeal face seal port



V-VacuSeal face seal port



Dimensions

Basic Part Number	End Connections		Dimensions Inches (mm)				
	Port 1	Port 2	A†	B†	C	D	E
2A-FT4	1/8" A-LOK®		1.14	1.14	0.51 (13.0)	1.53 (38.9)	0.88 (22.4)
2Z-FT4	1/8" CPI™		(29.0)	(29.0)			
2F-FT4	1/8" Female NPT		1.00	1.00			
			(25.4)	(25.4)			
2M-FT4	1/8" Male NPT		1.00	1.00			
			(25.4)	(25.4)			
4A-FT4	1/4" A-LOK®		1.23	1.23			
4Z-FT4	1/4" CPI™		(31.2)	(31.2)			
4F-FT4	1/4" Female NPT		1.06	1.06			
			(26.9)	(26.9)			
4M-FT4	1/4" Male NPT		1.09	1.09			
			(27.7)	(27.7)			
4Q-FT4	1/4" UltraSeal		1.09	1.09			
			(27.7)	(27.7)			
4V-FT4	1/4" VacuSeal		1.20	1.20			
			(30.5)	(30.5)			
M6A-FT4	6mm A-LOK®		1.23	1.23	0.59 (15.0)	1.71 (43.4)	1.25 (31.8)
M6Z-FT4	6mm CPI™		(31.2)	(31.2)			
6A-FT8	3/8" A-LOK®		1.42	1.42			
6Z-FT8	3/8" CPI™		(36.1)	(36.1)			
6M-FT8	3/8" Male NPT		1.19	1.19			
			(30.2)	(30.2)			
8A-FT8	1/2" A-LOK®		1.53	1.53			
8Z-FT8	1/2" CPI™		(38.9)	(38.9)			
8F-FT8	1/2" Female NPT		1.48	1.48			
			(37.6)	(37.6)			
8M-FT8	1/2" Male NPT		1.38	1.38			
			(35.1)	(35.1)			
8V-FT8	1/2" VacuSeal		1.33	1.33			
			(33.8)	(33.8)			
M8A-FT8	8mm A-LOK®		1.44	1.44			
M8Z-FT8	8mm CPI™		(36.6)	(36.6)			
M10A-FT8	10mm A-LOK®		1.44	1.44			
M10Z-FT8	10mm CPI™		(36.6)	(36.6)			
M12A-FT8	12mm A-LOK®		1.54	1.54			
M12Z-FT8	12mm CPI™		(39.1)	(39.1)			

† For CPI™ and A-LOK®, dimensions are measured with nuts in the finger tight position.

Maximum Pressure Differential Across Clean Filters at 70 °F (21 °C)

	1 micron	5 micron	10 micron	50 micron	100 micron	250 micron	450 micron
psig	2250	1950	1750	1150	1000	1000	1000
bar	155	134	120	79	69	69	69

How to Order

The correct part number is easily derived by following the circled number sequence. The six product characteristics required are coded as shown below. *Note: If both the inlet and outlet ports are the same, eliminate the outlet port designator.

Example: **4M** - * - **FT4** - **5** - **BN** - **B**

① ② ③ ④ ⑤ ⑥

Inlet **Outlet** **Valve** **Micron** **Seal** **Body**

Port **Port** **Series** **Rating** **Material** **Material**

Describes an FT Series Filter with 1/4" male NPT inlet and outlet ports, a 5 micron element, Buna-N seal and brass body construction.

① Inlet Port	② Outlet Port	③ Valve Series	④ Nominal Micron Rating	⑤ Seal Material	⑥ Body Material
2A, 2F, 2M, 2Z, 4A, 4F, 4M, 4Q, 4V, 4W, 4Z, M6A, M6Z		FT4	1 - 1 Micron 5 - 5 Micron 10 - 10 Micron	Blank - Fluorocarbon Rubber BN - Buna-N Rubber EPR - Ethylene Propylene Rubber	SS - Stainless Steel
6A, 6M, 8A, 8M, 8V, 8Z, M8A, M8Z, M10A, M10Z, M12A, M12Z		FT8	50 - 50 Micron 100 - 100 Micron 250 - 250 Micron 450 - 450 Micron	NE - Neoprene Rubber KZ - Highly Fluorinated Fluorocarbon Rubber HT - Silver Plated Nickel Alloy C-Ring T - PTFE	B - Brass

Options

Oxygen Cleaning – Add the suffix–**C3** to the end of the part number to receive filters cleaned and assembled for oxygen service in accordance with Parker specification ES8003. **Example:** 4A-FT4-10-V-SS-**C3**

Special Cleaning – All face seal ended filters are cleaned in accordance with Parker Specification ES8001. This is an option for all filters by adding the suffix–**C1** to the end of the part number. **Example:** M6A-FT8-50-NE-SS-**C1**.

Bypass – Add the suffix–**PB** to the end of the part number to receive a 1/8" –27 FNPT tapped Cap for sampling. **Example:** 2M-FT4-5-V-SS-**PB**

Integral Compression Ported Bypass Option – Add the suffix–**PBA** (A-LOK®) or–**PBZ** (CPI™) to the end of the part number to receive a 4Z/4A (FT4) or 6A/6Z (FT8) compression ported Cap.

Example: 2M-FT4-5-V-SS-**PBZ**

Kit Information

To order repair kits for the FT Series Filters, simply fill in the designators from the chart below.

Size	Micron Rating	Seal Material
FT4	1	V - Fluorocarbon Rybber
	5	BN - Buna-N Rubber
	10	EPR - Ethylene Propylene Rubber
FT8	50	NE - Neoprene Rubber
	100	KZ - Highly Fluorinated Fluorocarbon Rubber
	250	
	450	HT - Silver Plated Nickel Alloy C-Ring

Examples: **KIT-FT4-10-V**
KIT-FT8-100-BN

Filter Kits Contain: Seals, Filter Element, Spring and Maintenance Instructions.

Caution: When interchanging sintered metal elements with wire cloth filter elements, the flow direction is reversed.

WARNING

FAILURE, IMPROPER SELECTION OR IMPROPER USE OF THE PRODUCTS AND/OR SYSTEMS DESCRIBED HEREIN OR RELATED ITEMS CAN CAUSE DEATH, PERSONAL INJURY AND PROPERTY DAMAGE.

This document and other information from Parker Hannifin Corporation, its subsidiaries and authorized distributors provide product and/or system options for further investigation by users having technical expertise. It is important that you analyze all aspects of your application and review the information concerning the product or system in the current product catalog. Due to the variety of operating conditions and applications for these products or systems, the user, through its own analysis and testing, is solely responsible for making the final selection of the products and systems and assuring that all performance, safety and warning requirements of the application are met.

The products described herein, including without limitation, product features, specifications, designs, availability and pricing, are subject to change by Parker Hannifin Corporation and its subsidiaries at any time without notice.

Offer of Sale

The items described in this document are hereby offered for sale by Parker Hannifin Corporation, its subsidiaries or its authorized distributors. This offer and its acceptance are governed by the provisions stated in the "Offer of Sale" located in Catalog 4110-U Needle Valves (U Series).

© Copyright 2003, Parker Hannifin Corporation. All Rights Reserved.

Pressure vs. Temperature

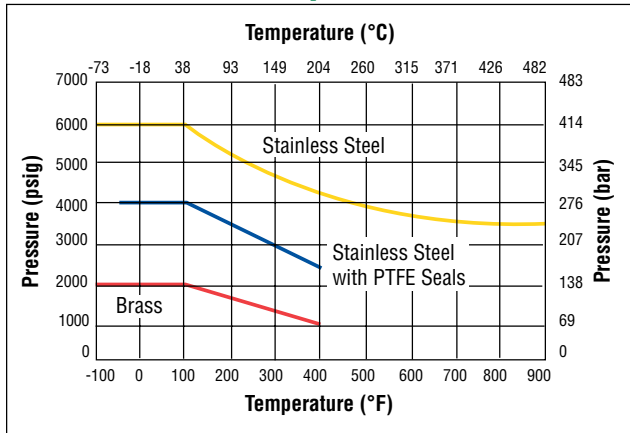

Note: To determine MPa, multiply bar by 0.1

Note: This Pressure versus Temperature chart reflects the maximum temperature range of indicated body materials.

The temperature rating of the seal becomes the limiting factor on temperature range.

Temperature Ratings:

Buna-N Rubber

-40 °F to 275 °F (-40 °C to 135 °C)

Highly Fluorinated Fluorocarbon Rubber

-20 °F to 500 °F (-29 °C to 260 °C)

Ethylene Propylene Rubber

-70 °F to 300 °F (-57 °C to 149 °C)

Fluorocarbon Rubber

-40 °F to 400 °F (-40 °C to 204 °C)

Neoprene Rubber

-65 °F to 300 °F (-54 °C to 149 °C)

Silver Plated Nickel Alloy Gasket (C-ring)

-100 °F to 900 °F (-73 °C to 482 °C)

PTFE

-70 °F to 400 °F (-56 °C to 204 °C)

Flow Calculations with 100 psig (7 bar) Inlet Pressure

Pressure Drop ΔP		FT4				FT8			
		Water GPM at 60 °F (16 °C)	Water m³/hr at 60 °F (16 °C)	Air SCFM at 60 °F (16 °C)	Air m³/hr at 60 °F (16 °C)	Water GPM at 60 °F (16 °C)	Water m³/hr at 60 °F (16 °C)	Air SCFM at 60 °F (16 °C)	Air m³/hr at 60 °F (16 °C)
psig	bar	1 Micron				1 Micron			
5	0.35	0.16	0.04	1.69	2.68	0.28	0.06	2.89	4.58
10	0.69	0.23	0.05	2.35	3.72	0.39	0.09	4.02	6.36
50	3.45	0.51	0.12	4.63	7.18	0.87	0.20	7.91	12.26
		5 Micron				5 Micron			
5	0.35	0.35	0.08	3.68	5.84	0.77	0.17	8.05	12.76
10	0.69	0.50	0.11	5.13	8.12	1.08	0.25	11.21	17.74
50	3.45	1.11	0.25	10.10	15.65	2.43	0.55	22.07	34.19
		10 Micron				10 Micron			
5	0.35	0.44	0.10	4.57	7.26	0.94	0.21	9.90	15.70
10	0.69	0.62	0.14	6.37	10.09	1.33	0.30	13.79	21.83
50	3.45	1.38	0.31	12.55	19.44	2.98	0.68	27.15	42.07
		50 Micron				50 Micron			
5	0.35	0.52	0.12	5.42	8.59	0.99	0.23	10.42	16.52
10	0.69	0.73	0.17	7.55	11.95	1.40	0.32	14.51	22.97
50	3.45	1.63	0.37	14.86	23.03	3.14	0.71	28.57	44.26
		100 Micron				100 Micron			
5	0.35	0.65	0.15	6.78	10.75	1.64	0.37	17.22	27.31
10	0.69	0.91	0.21	9.45	14.95	2.32	0.53	23.99	37.97
50	3.45	2.04	0.46	18.60	28.81	5.19	1.18	47.23	73.17
		250 Micron				250 Micron			
5	0.35	1.14	0.26	11.94	18.92	1.74	0.40	18.22	28.88
10	0.69	1.62	0.37	16.56	26.17	2.47	0.56	25.28	39.95
50	3.45	3.61	0.82	31.30	48.07	5.52	1.25	47.78	73.37
		450 Micron				450 Micron			
5	0.35	1.23	0.28	12.84	20.35	1.88	0.43	19.64	31.13
10	0.69	1.74	0.39	17.82	28.17	2.66	0.60	27.27	43.10
50	3.45	3.88	0.88	33.92	52.16	5.94	1.35	51.89	79.81

Flow / Filtration Data

Filter Series	Effective Filtration Area		$C_t \dagger$						
			1 micron	5 micron	10 micron	50 micron	100 micron	250 micron	450 micron
	sq in	sq mm	Micron Range .5 to 3	Micron Range 5 to 10	Micron Range 10 to 20	Micron Range 40 to 50	Micron Range 100 to 150	Micron Range 225 to 275	Micron Range 400 to 500
FT4	1.57	1012	0.072	0.157	0.195	0.231	0.289	0.511	0.549
FT8	2.53	1632	0.123	0.343	0.422	0.444	0.734	0.780	0.840

† Tested in accordance with ISA S75.02. Gas flow will be choked when $P_1 - P_2 / P_1 = x_T$.

$x_T=1.0$ for micron sizes 1 through 100; 0.78 for the 250 micron size, and 0.81 for the 450 micron size.



Catalog 4130-FT, 20M, 05/03

Parker Hannifin Corporation
Instrumentation Valve Division
2651 Alabama Highway 21 North
Jacksonville, AL 36265-9681
USA
Phone: (256) 435-2130
Fax: (256) 435-7718
www.parker.com/ivd

Parker Hannifin plc
Instrumentation Products Division
Riverside Road
Pottington Business Park
Barnstaple, Devon EX31 1NP
England
Phone: +44 (0) 1271 313131
Fax: +44 (0) 1271 373636
Email: ipd@parker.com
www.parker.com/ipd